

# XFP Host Test Board

timbercon

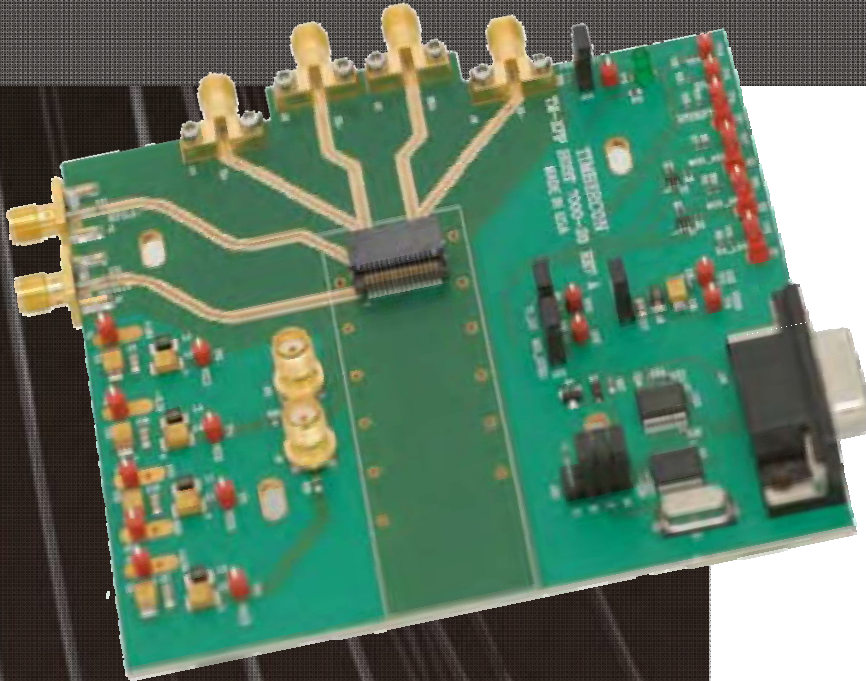
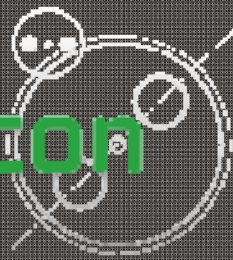

## BENEFITS

- Allows Customization of XFP Loopback and Transceiver Memory Maps
- Enables Low Loss Testing and Evaluation of XFP Transceiver Modules

## APPLICATIONS

- Custom XFP Loopback and Memory Map Programming
- XFP Loopback Testing
- In-coming Inspection Testing of XFP Transceivers
- Analysis and Testing of XFP Transceiver Modules

## FEATURES

- XFP MSA Compliant
- Built with Rogers 3003 PC Board Material
- SMA Connectors for High-Speed Data
- Integrated RS-232 to I2C Converter
- Power Supply Port
- Transmit and Receive Ports
- Reference Clock Port
- Operations Software and Schematics Provided

### XFP Host Test Board

Timbercon XFP Host Test Boards are designed to provide an efficient and easy method of programming and testing XFP Electrical Loopbacks and Transceivers.

The XFP Host Test Board comes complete with operations software and user manual to enable XFP memory map programming and testing. The board features transmit, receive, computer interface, reference clock, and power supply ports.

The XFP Host Test Board is designed to simulate an ideal environment for XFP module testing using Rogers 3003 PC board material and single-ended micro-strip transmission lines. These properties make the host board as electrically transparent as possible, allowing a more accurate assessment of the modules' performance.

### Status LEDs

Status LEDs are connected to the low-speed output signals from the XFP module. The LED will illuminate when the signal is asserted.

### DS3900 Compatibility

The DS3900 is frequently used for programming digital potentiometer and controller ICs that are often used in optical modules. The Timbercon XFP Host Test Board uses similar hardware and the same firmware as the DS3900 for the serial to I2C conversion. Therefore the same software that was used with the DS3900 to control digital diagnostic ICs can be used with the Timbercon XFP Host Test Board.

### Software

Includes software to configure all the critical parameters of the XFP device. The software communicates to the board through an easy-to-use USB connection. The software is Windows® based and is designed to operate on Windows 98 and above.

### Supply Filter

The XFP Host Test Board is required to provide supply decoupling for transmitter and receiver supply voltages. The Timbercon XFP Host Test Board is designed with the recommended filters as per the XFP MSA.

## PREMIUM SOLUTIONS

# XFP Host Test Board

(Typical values are measured at TA = +25°C)

## TYPICAL PERFORMANCE

Parameter	Symbol	Conditions	Typ	Units
Transmission line Characteristic Impedance	Z	Odd Mode Impedance	50 ±10%	Ω
Differential S11 Magnitude (Notes 1, 2)		f < 7.5 GHz (Notes 1, 2)	-10	dB
		f < 10 GHz (Notes 1, 2)	-5	
S21 f3 dB Point	f3 dB	Notes 1,3	8	GHz
S21 f6 dB Point	f6 dB	Notes 1,3	11	GHz

\*Measurements performed by MAXIM Intergrated Products

Note 1: S-Parameter measurements were made using a four-port network analyzer operating in differential mode.

Note 2: Measured at RD- and RD+ or TD+ and TD-SMA connections. Measurement includes the XFP connector with a 50Ω termination at end of an XFP adaptor test board.

Note 3: S21 measurement path includes the transmission loss added by the adaptor test board.

## XFP TEST SETUP

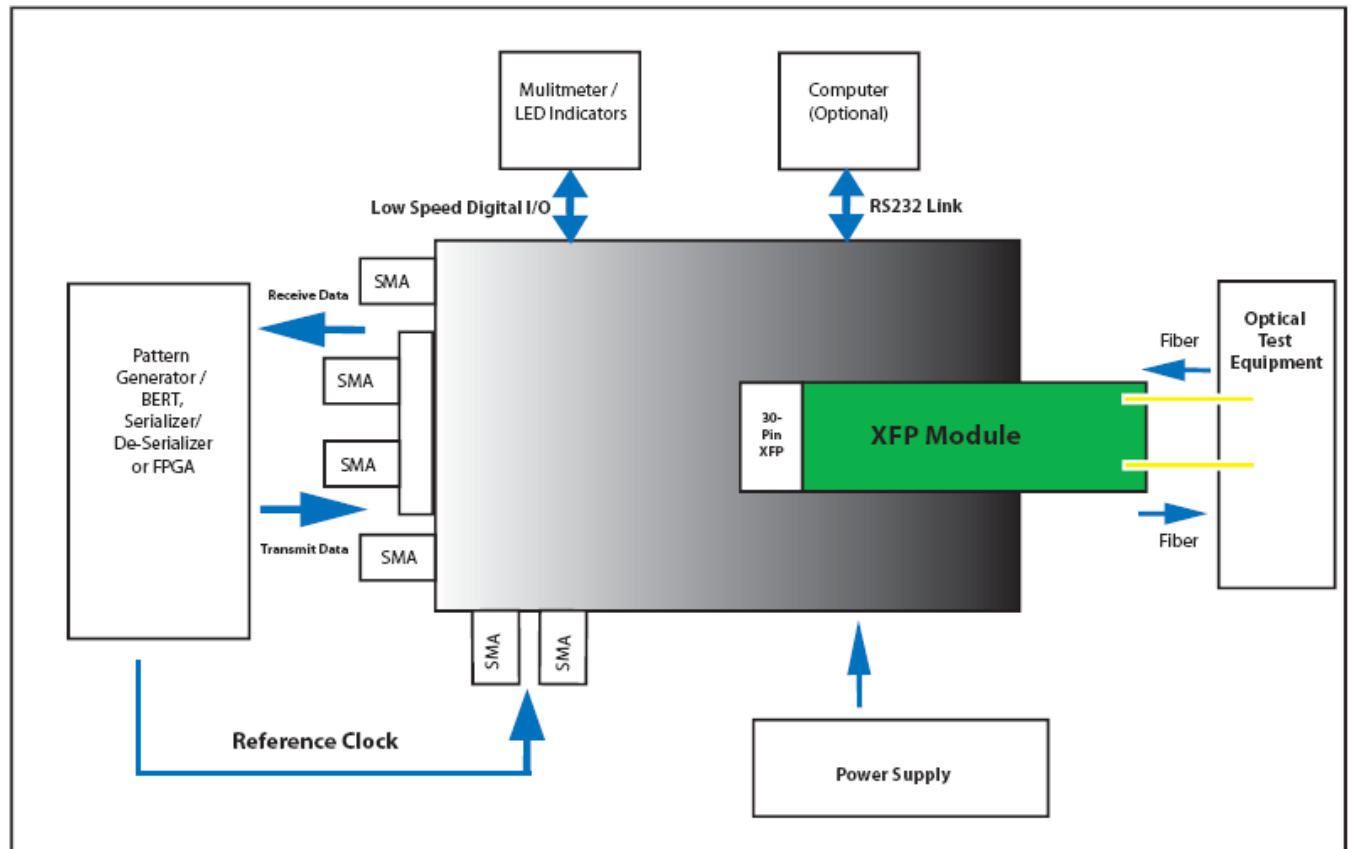

## ABOUT

Founded in 1997, Timbercon, Inc. is a fiber optic product and solution manufacturing company providing a vast array of connectivity solutions to the data storage, telecommunications, military, industrial, broadcast and networking industries. In addition to standard fiber optic patch cords and attenuated test cables, Timbercon has pioneered proprietary products, many of which are now considered to be an industry benchmark.

